

160Ø
2038630 2038631 2038634
2038635 2038654 2038655
185Ø
2038638 2038640 2038646
2038647 2038658 2038660
215Ø
2038651 2038652

Disconnect from mains supply before replacing the fuse or the lamp.
Vor dem Einsetzen der Sicherung oder der Lampe Spannungsfreiheit herstellen.
Débrancher le secteur avant de remplacer le fusible ou l'ampoule.
Desconectar del suministro de la red, antes de realizar la sustitución del fusible o de la lámpara.
Voor het vervangen van lamp of zekering, eerst netspanning uitschakelen.
Koppla bort spänningen före byte av en säkring eller en lampa.

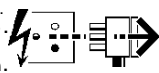

Switch Off
Abschalten
Couper le conector
Desconectar
Uitschakelen
Stäng av

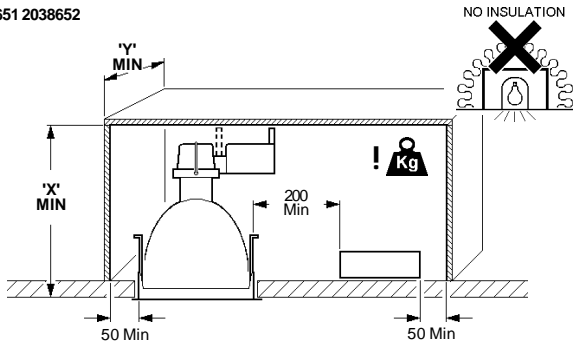

IP20 Luminaire Only		IP44 Installer Pack		Luminaire Only	
'X' MIN	'Y' MIN	'X' MIN	'Y' MIN	'X' MIN	'Y' MIN
2038646 = 270	380	2038630 = 230	335	2038654 = 230	335
2038647 = 195	300	2038631 = 190	300	2038655 = 190	300
2038651 = 280	380	2038634 = 230	335		
2038652 = 260	380	2038635 = 190	300		
		2038638 = 235	335	2038658 = 235	335
		2038640 = 215	315	2038660 = 215	315

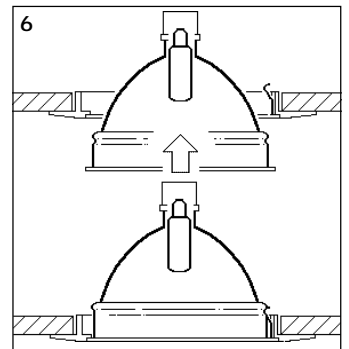
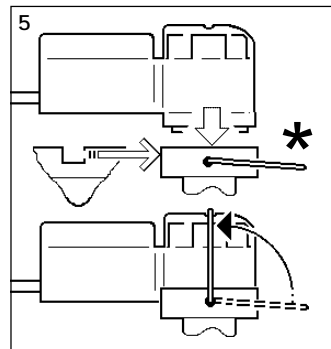
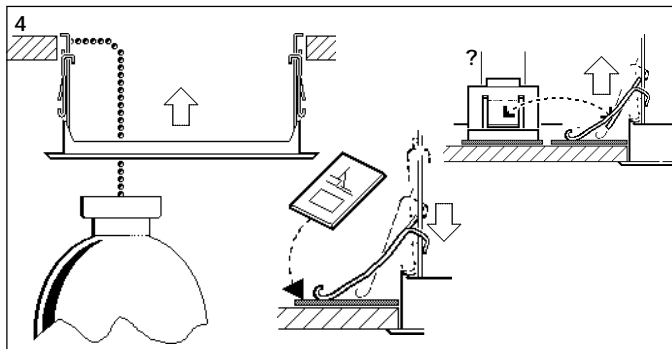
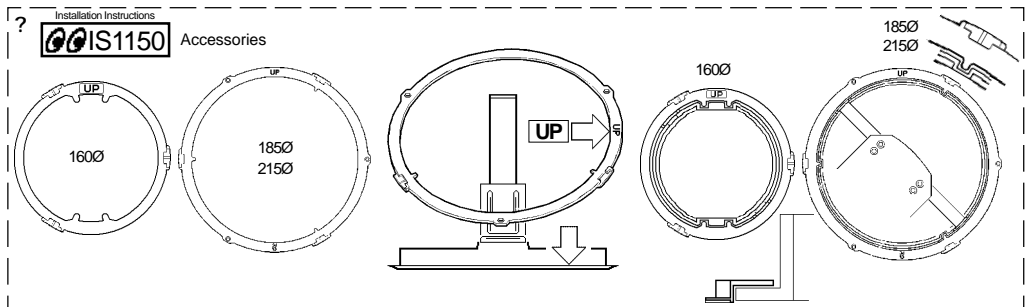
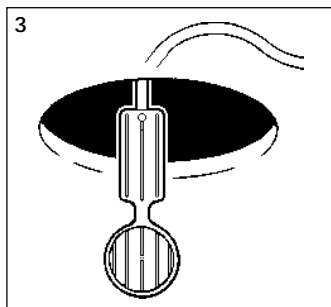
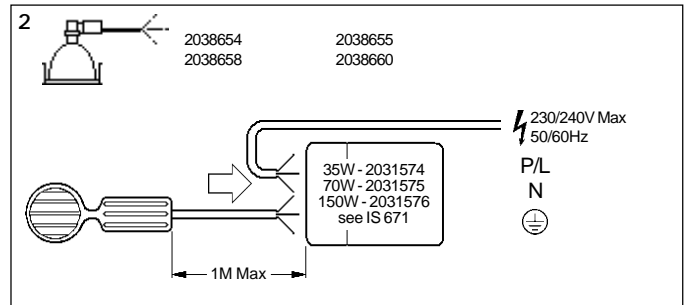
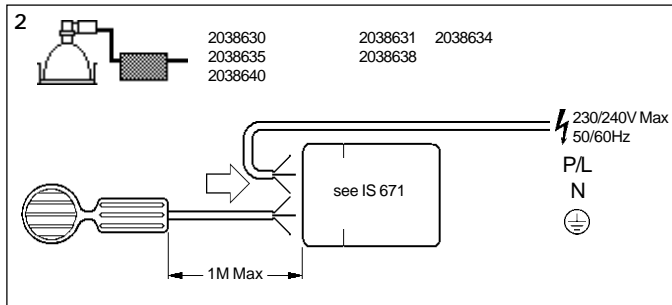
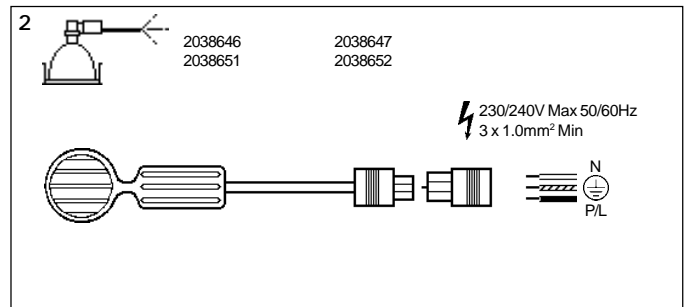
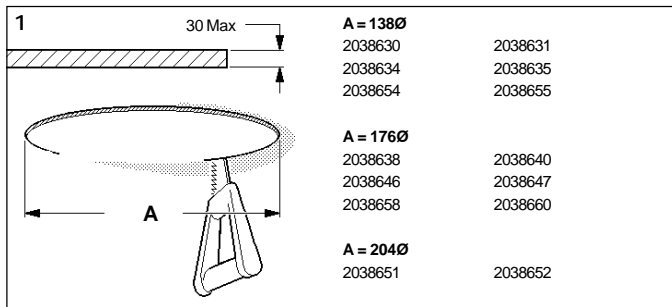

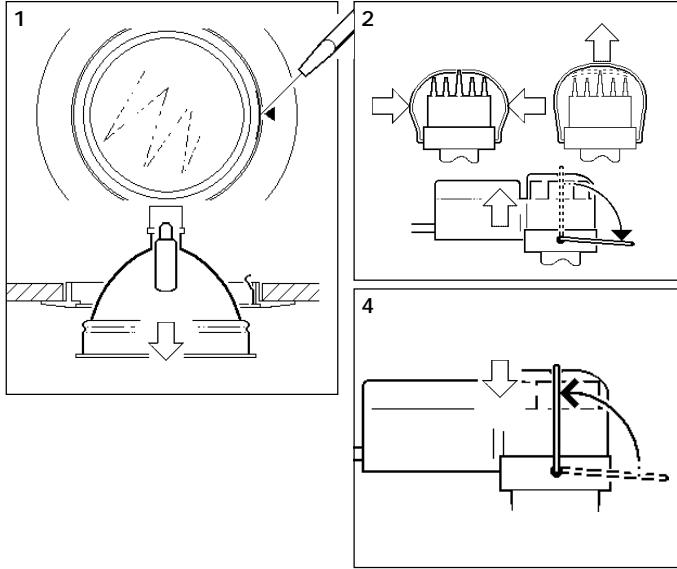

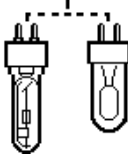

3 *

35/70/150W CDMT G12
or
35/70/150W HIT G12

35W
2038630 2038631
35W/70W
2038654 2038655
70W
2038634 2038635
150W
2038638 2038640
2038658 2038660

NO DIMMERS

150/250W
TH DLX-T E27

150W Max.
2038646 2038647
250W Max
2038651 2038652

330 Max.

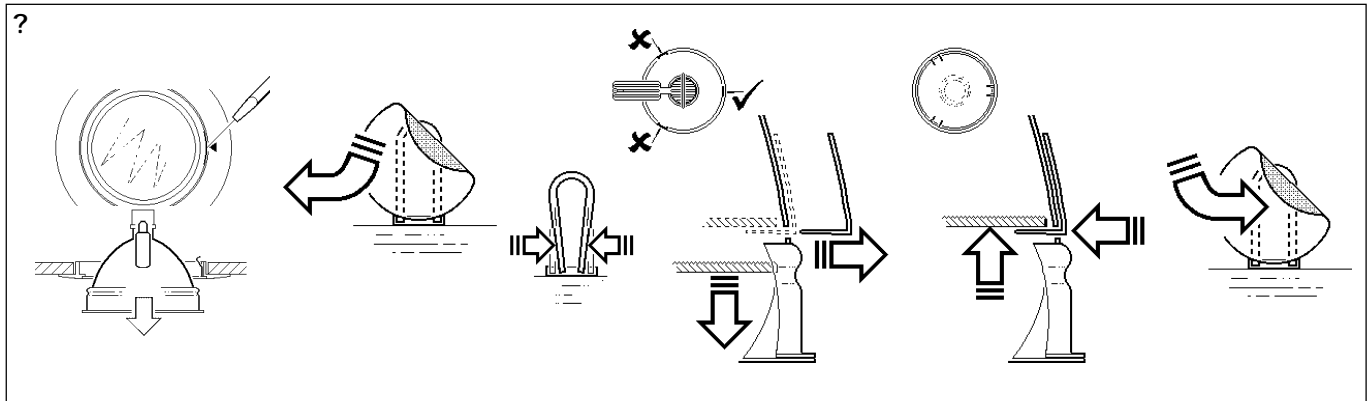
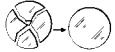

- Installer Pack**
- 2038630 = 1.5Kg
 - 2038631 = 1.5Kg
 - 2038634 = 1.5Kg
 - 2038635 = 1.5Kg
 - 2038638 = 1.9Kg
 - 2038640 = 1.9Kg

UV STOP = Lamp - UV Glass/Coated

 = Emergency Lighting - (2031573 see IS674)

'Equinox' is a registered Trade Mark: UK 1342654, Japan 2617325

Suitable for use indoors
Geeignet für Innenanwendung
Pour un usage interne
Adecuada para uso en interiores
Geschikt voor gebruik binnen
Lämplig för inomhusbruk



 **Replace any cracked protective shield.**
Dieses symbol bedeutet, dass defekte Schutzgläser sofort ersetzt werden müssen.
Ce symbol indique que vous devez remplacer tout verre de protection fêlé.
Este simbolo indica que hay que 'reemplazar filtros en caso de rotura o desperfectos'.
Dette symbolet indikerer at alle ødelagte (sprukne) sikkerhetglass må skiftes.
Valaisinta el saa käyttää ilman suojalasia vioittunut suojalasi on vaihdettava uuteen ennen valaisimen käyttöön ottoa.

< Millimetres >



This Electrical Product
MUST be recycled.



05.08

Concord

Avis Way Newhaven East Sussex BN9 0ED
T 0870 606 2030 F 01273 512 688 email: information@concordmarlin.com



© Concord Lighting Ltd.