

Ascent 150 Wallwasher



IS1373D

2050749
2052645
2052718
2052724

Disconnect from mains supply before replacing the fuse or the lamp.
Vor dem Einsetzen der Sicherung oder der Lampe Spannungsfreiheit herstellen.
Débrancher le secteur avant de remplacer le fusible ou l'ampoule.
Desconectar del suministro de la red, antes de realizar la sustitución del fusible o de la lámpara.
Voor het vervangen van lamp of zekering, eerst netspanning uitschakelen.
Koppla bort spänningen före byte av en säkring eller en lampa.

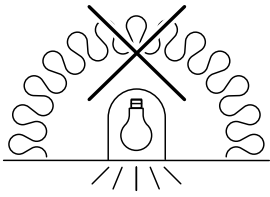
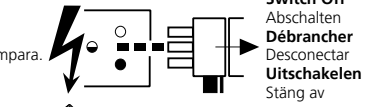

Not suitable for covering with thermally insulating material
Ne doit pas être recouvert un matériau isolant thermique

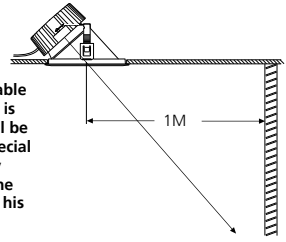
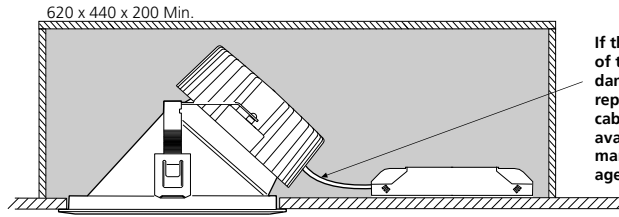

1

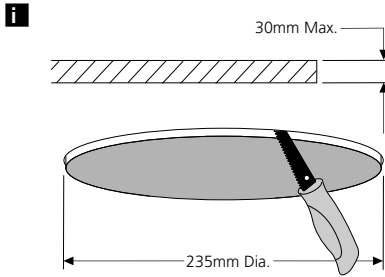

ii ⚡ 230-240V
2 x 1.0mm² Min.

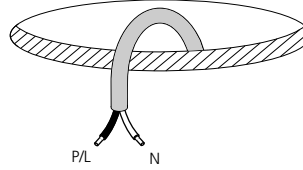

2 IS1150

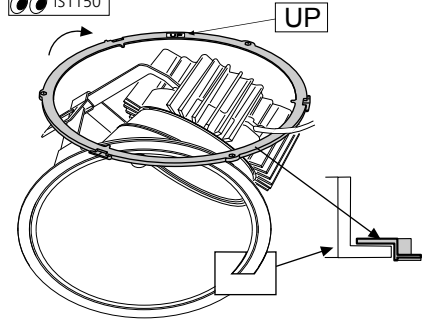

2

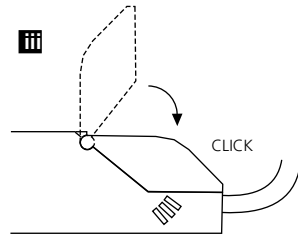
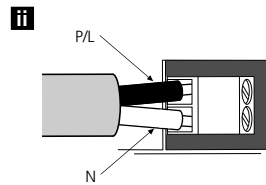
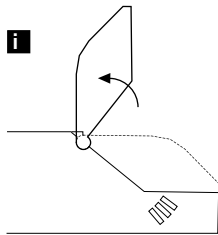

3

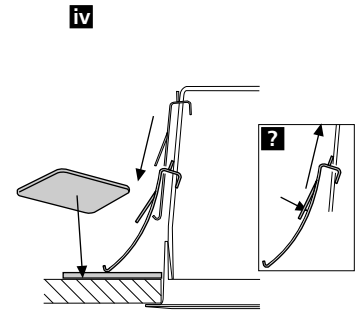
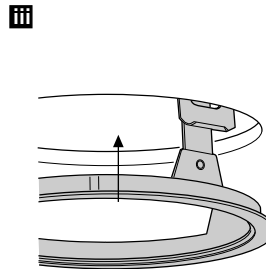
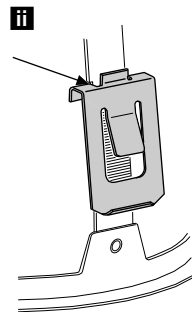
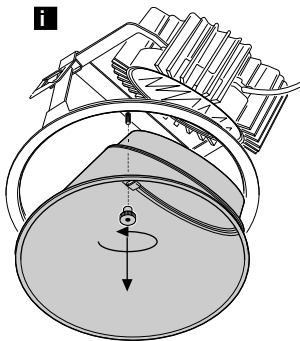

4

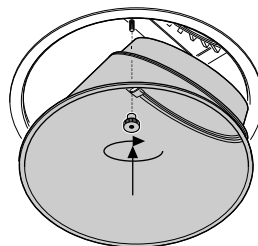

Suitable for use indoors
Geeignet für Innenanwendung
Pour un usage interne
Adecuada para uso en interiores
Geschikt voor gebruik binnen
Lämpligt för inomhusbruk



This Electrical Product **MUST** be recycled.

Concord

Havells Sylvania Europe LTD
Avis Way, Newhaven East Sussex BN9 0ED UK
www.havells-sylvania.com



© Concord Lighting Limited 09.12