

3097116-3097119
 3097124-3097155
 3097156-3097163
 3097182-3097193
 3097203-3097209
 3097212-3097216

kg 150 Standard = 1.5Kg
 150 Emergency = 2.20Kg
 175 Standard = 1.5Kg
 175 Emergency = 2.20Kg

Disconnect from mains supply before replacing the fuse or the lamp.
 Vor dem Einsetzen der Sicherung oder der Lampe Spannungsfreiheit herstellen.
Débrancher le secteur avant de remplacer le fusible ou l'ampoule.
 Desconectar del suministro de la red, antes de realizar la sustitución del fusible o de la lámpara.
Voor het vervangen van lamp of zekering, eerst netspanning uitschakelen.
 Koppla bort spänningen före byte av en säkring eller en lampa.

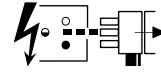

Switch Off
 Abschalten
Débrancher
 Desconectar
Uitschakelen
 Stäng av

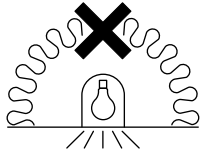

Not suitable for covering with thermally insulating material
 Ne doit pas être recouvert un matériau isolant thermique

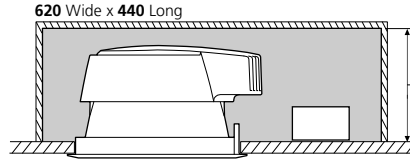

150 Std.
 3097116-3097123, 3097132-3097139, 3097182-3097185
 = 100
 175 Std.
 3097148-3097155, 3097188 3097189
 = 100
 150 Low Glare
 3097124-3097131, 3097140-3097147, 3097186 3097187
 = 125
 175 Low Glare
 3097156-3097163, 3097190 3097191
 = 150

1

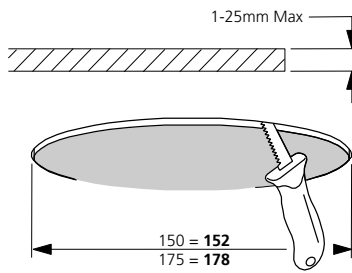

2 Accessory - 3097171 3004882

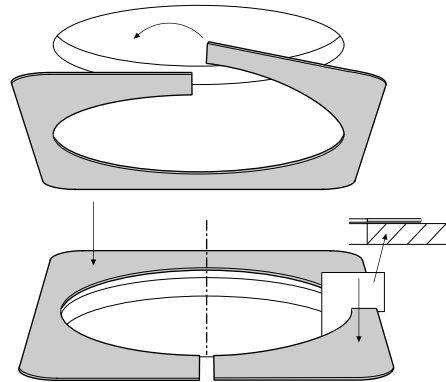

3a Insaver 150 Standard
 3097182 - 7
 3097192 - 4
 3097197 - 9

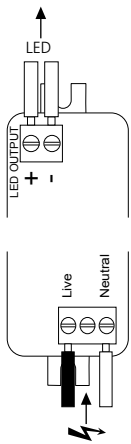

3b Insaver 150 1-10V Dimming
 3097116 - 7
 3097124 - 5
 3097132 - 3
 3097140 - 1

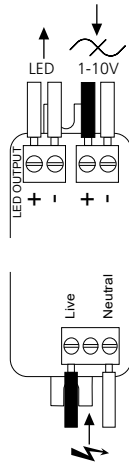

3c Insaver DALI
 3097120 - 1
 3097128 - 9
 3097136 - 7
 3097144 - 5

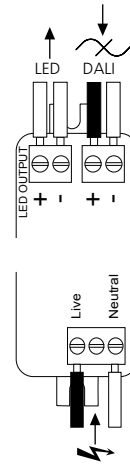

3d Insaver 175
 3097188 - 3097191, 95, 95

1-10V
 3097148 - 9 3097156 - 7

DALI
 3097152 - 3 3097160 - 1



4

i

? Accessory - 3097166 3097167 3097169
 3097170 3097174 3097175

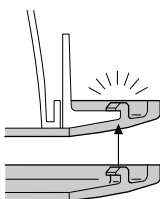

ii

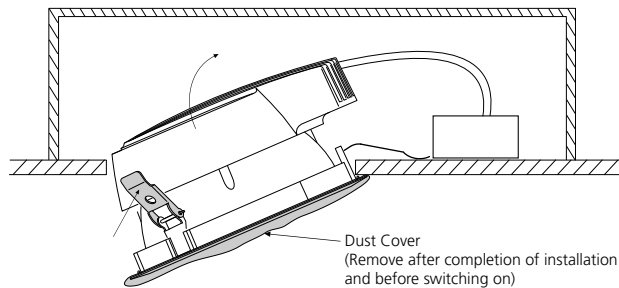

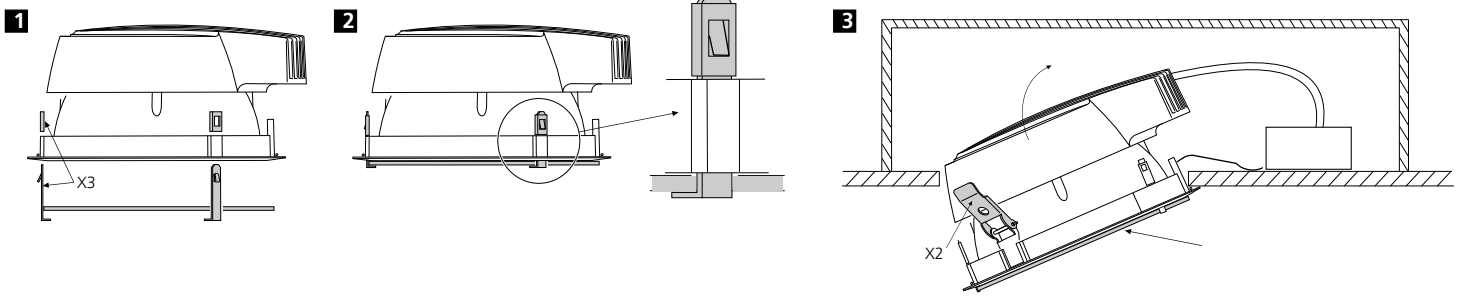

Emergency

- 3097118 3097119 3097122 3097123 3097126 3097127 3097130 3097131
- 3097134 3097135 3097138 3097139 3097142 3097143 3097146 3097147
- 3097150 3097151 3097154 3097155 3097158 3097159 3097162 3097163
- 3097203-3097209 3097212-3097216

COMMISSIONING DATE	JAN	FEB	MAR	APR
	MAY	JUN	JUL	AUG
	SEP	OCT	NOV	DEC
	2010	2011	2012	2013
	2014	2015	2016	2017
	2018	2019	2020	2021

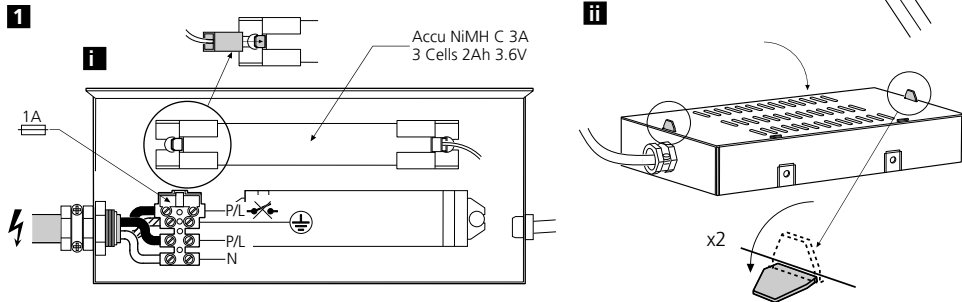

Routine Testing

- Testing should be carried out in accordance with the recommendations of BS5266.
1. A monthly functional test.
 2. Twice yearly, a one hour test.
 3. Every three years, a full three hour duration test.
- The above tests assume a three hour system.
4. Batteries should be replaced when the luminaire no longer meets the 3 hours duration performance.
 5. Testing could be performed by interrupting the fixed phase supply for the test duration, during which the luminaire should remain lit.
 6. Ensure that the 'LED' is 'OFF' during 'Discharge Mode', and 'ON' during 'Charging Mode'.
 7. Replace faulty lamps immediately.

To assist with this testing, a test card is included below.

If the charge indicator (LED) is unlit, this signifies a fault. To increase the chance of a fault being reported between monthly tests, it is desirable that staff are made aware of the purpose of the indicator.

This module should not be modified or repaired by any person other than those nominated by the manufacturer. ANY unauthorised modifications may render the module unsafe and will invalidate our warranty and conformance to any safety standards that may apply. The company will accept no responsibility for any modified modules, or for damage caused as a result of modifications.

All details are given for guidance only and do not constitute a contract. We reserve the right to change the characteristics of products without notice.

Test Record

Type:.....	Location:.....	1st Year	2nd Year	3rd Year	4th Year	5th Year
1. Functional						
2. Functional						
3. Functional						
4. Functional						
5. Functional						
6. Functional						
7. Functional						
8. Functional						
9. One Hour						
Three Hour						
10. Functional						
11. Function						
12. Functional						

Suitable for use indoors
 Geeignet für Innenanwendung
Pour un usage interne
 Adecuada para uso en interiores
Geschikt voor gebruik binnen
 Lämplig för inomhusbruk

Replace any cracked protective shield.
 Dieses symbol bedeutet, dass defekte Schutzgläser sofort ersetzt werden müssen.
Ce symbol indique que vous devez remplacer tout verre de protection fêlé.
 Este simbolo indica que hay que 'reemplazar filtros en caso de rotura o desperfectos'.
Dette symbolet indikerer at alle ødelagte (sprukne) sikkerhetglass må skiftes.
 Valaisinta el saa käyttää ilman suojalasia vioitunut suojalasi on vaihdettava uuteen ennalaisimen käyttöön ottoa.