

Disconnect from mains supply before replacing the fuse or the lamp.
Vor dem Einsetzen der Sicherung oder der Lampe Spannungsfreiheit herstellen.
Débrancher le secteur avant de remplacer le fusible ou l'ampoule.
Desconectar del suministro de la red, antes de realizar la sustitución del fusible o de la lámpara.
Voor het vervangen van lamp of zekering, eerst netspanning uitschakelen.
Koppla bort spänningen före byte av en säkring eller en lampa.

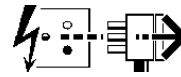

Switch Off
Abschalten
Débrancher
Desconectar
Uitschakelen
Stång av

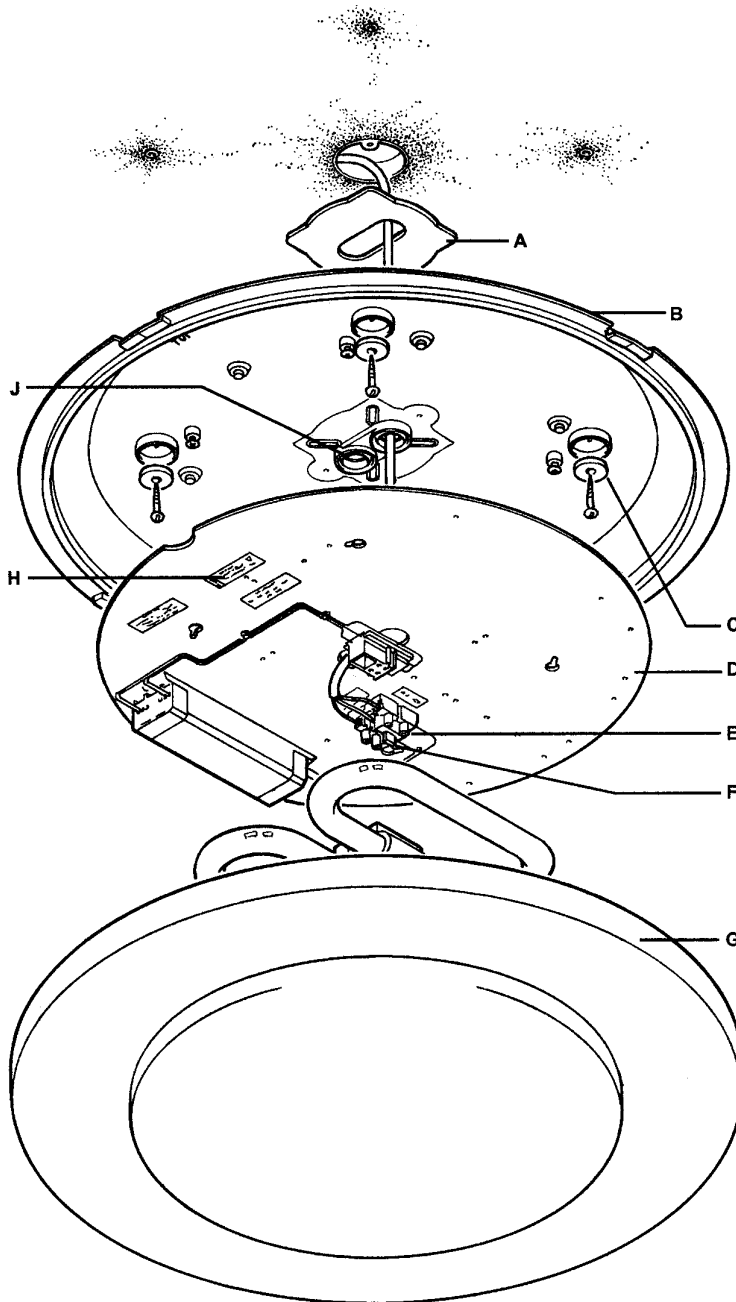

Checklist:

- 1. Gasket 2. Grommet 3. Silicone Sleeving 4. Seal Washers

Installation Instructions

Remove trim/diffuser assembly (G). See Fig.3.

Loosen gear tray fixing screws and remove gear tray (D).

Prepare suitable fixings in wall or ceiling at 210mm centres - see Fig. 1.

NOTE: Housing (B) is marked TOP if wall mounting.

Drill 5mm diameter outrigger holes in housing, and M4 clearance holes if fixing to conduit box.
NOTE: Outrigger holes must be used in all installations.

Stick sealing gasket (A) on housing (B).

Fit supplied grommets (J) in housing - see Fig. 2.

Pierce and pass mains supply cable through grommet/s.

Secure housing (B) to mounting surface using suitable fixing screws and seal washers (C). If applicable secure housing to conduit box with M4 screws.
NOTE: Sealing side of washer to face housing.

NOTE: Apply waterproof sealant around supply cable, grommets and heads of all housing screws.

Pass supply cable through gear tray (D) and fit gear tray.
NOTE: Tray will only fit in one position.

Cover all electrical supply cable leads with supplied silicone sleeving.

Connect cable leads in respectively marked terminals in terminal block (E).

Fit appropriate lamp (38W TC-DE) as indicated on label (H).

Fit trim/diffuser assembly (G), see Fig. 3.

NOTE: Luminaire is protected by 3A fuse (F).

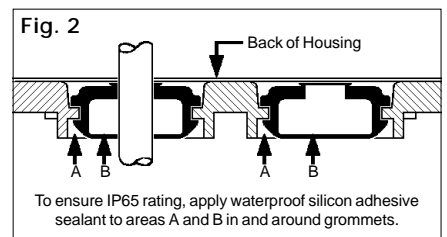
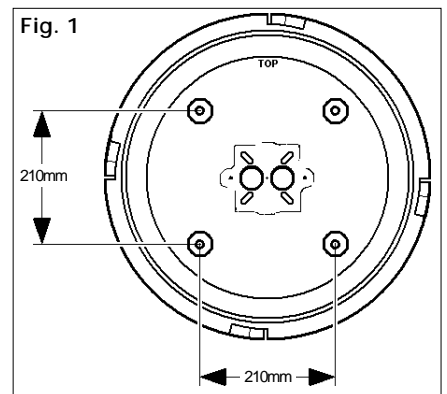

Removing Diffuser Assembly.
Using a M4 socket key, unscrew (A) out a minimum of 4mm. Depress (B) down 2mm, and rotate trim/diffuser (C) anti-clockwise.

Fitting Trim/Diffuser Assembly.
Rotate clockwise until it clicks into position and tighten screw (A) until flush as shown.

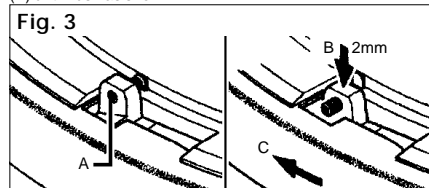

Suitable for use indoors
Geeignet für Innenanwendung
Pour un usage interne
Adecuada para uso en interiores
Geschikt voor gebruik binnen
Lämplig för inomhusbruk



Replace any cracked protective shield.
Dieses symbol bedeutet, dass defekte Schutzgläser sofort ersetzt werden müssen.
Ce symbole indique que vous devez remplacer tout verre de protection fêlé.
Este símbolo indica que hay que 'reemplazar filtros en caso de rotura o desperfectos'.
Dette symbolet indikerer at alle ødelagte (sprukne) sikkerhetglass må skiftes.
Valaisinta ei saa käyttää ilman suojalasiasa vioitunut suojalasi on vaihdettava uuteen ennen valaisimen käyttöön ottoa.

< Millimetres >

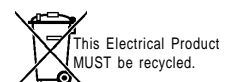

11.07