

Fluorescent Unit - Pull Switch

9919 CS 21 Super Slim

Installation Instructions This Product **MUST** be EARTHED

IS1135A

Disconnect from mains supply before replacing the fuse or the lamp.
 Vor dem Einsetzen der Sicherung oder der Lampe Spannungsfreiheit herstellen.
Débrancher le secteur avant de remplacer le fusible ou l'ampoule.
 Desconectar del suministro de la red, antes de realizar la sustitución del fusible o de la lámpara.
Voor het vervangen van lamp of zekering, eerst netspanning uitschakelen.
 Koppla bort spänningen före byte av en säkring eller en lampa.

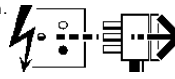

Switch Off
 Abschalten
Débrancher
 Desconectar
Uitschakelen
 Stäng av

9919 CS 21 Super Slim Fluorescent Unit Pull Switch

To fit the Pull Switch:

Pass the cord and switch stem through the hole in the gallery. Thread the pull cord through the switch cap and screw the cap onto the switch stem to retain the switch in position.

Thread the pull cord through the bead. Tie a knot in the pull cord such that the tail of the knot does not project from the end of the bead when the knot is pulled into the bead.

If the luminaire is to be used without the pull switch, then for safety reasons the blanking plug supplied should be fitted into the hole in the gallery and the switch should be removed as detailed below.

To remove the Pull Switch:

Loosen the pull switch terminal screws and the Live (L) terminal screw on the terminal block.

Remove and discard the pull switch and the wire connecting the pull switch to the terminal block.

Connect the wire from the choke to the Live (L) terminal of the terminal block.

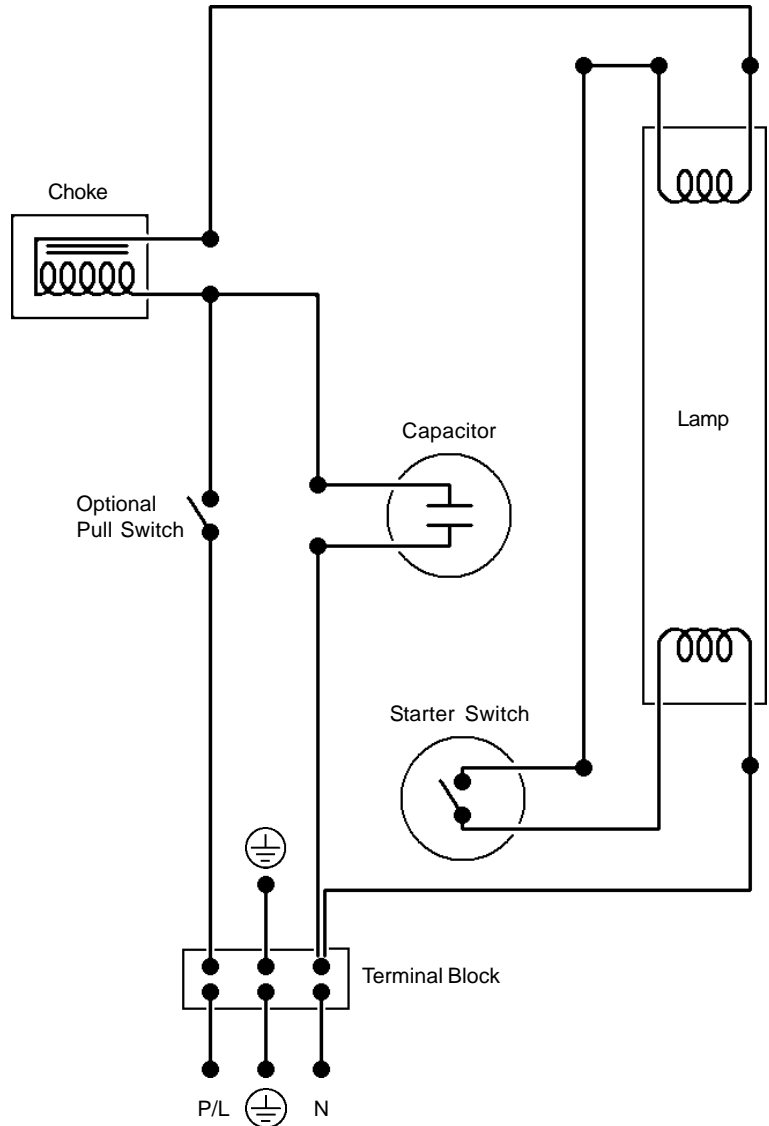

Suitable for use indoors
 Geeignet für Innenanwendung
Pour un usage interne
 Adecuada para uso en interiores
Geschikt voor gebruik binnen
 Lämplig för inomhusbruk



Replace any cracked protective shield.

Dieses symbol bedeutet, dass defekte Schutzgläser sofort ersetzt werden müssen.

Ce symbole indique que vous devez remplacer tout verre de protection fêlé.

Este símbolo indica que hay que 'reemplazar filtros en caso de rotura o desperfectos'.

Dette symbolet indikerer at alle ødelagte (sprukne) sikkerhetglass må skiftes.

Valaisinta ei saa käyttää ilman suojalasiasa vioitunut suojalasi on vaihdettava uuteen ennen valaisimen käyttöön ottoa.

< Millimetres >



This Electrical Product **MUST** be recycled.



01.09

Concord

Avis Way Newhaven East Sussex BN9 0ED
 T 0870 606 2030 F 01273 512 688 email: information@concordmarlin.com

