

2642008  
2642009  
2642010  
2642011

**Disconnect from mains supply before replacing the fuse or the lamp.**  
Vor dem Einsetzen der Sicherung oder der Lampe Spannungsfreiheit herstellen.  
**Débrancher le secteur avant de remplacer le fusible ou l'ampoule.**  
Desconectar del suministro de la red, antes de realizar la sustitución del fusible o de la lámpara.  
**Voor het vervangen van lamp of zekering, eerst netspanning uitschakelen.**  
Koppla bort spänningen före byte av en säkring eller en lampa.

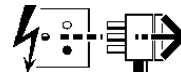

**Switch Off**  
Abschalten  
**Couper le connectar**  
Desconectar  
**Uitschakelen**  
Stäng av

**WARNING - This Low Voltage fitting should not be operated by a dimmer, unless the dimmer is specifically rated as suitable for Low Voltage equipment.**  
VORSICHT - Diese Niederspannungskörper dürfen nicht mit einem abblendregler betrieben werden, es sei denn der Abblendregler wurde für Niederspannungsgeräte als speziell geeignet bemessen.  
**AVERTISSEMENT - Cet accessoire a basse tension ne devra pas être actionné par un gradateur, sauf si ce gradateur est spécifiquement adapté a un matériel basse tension.**  
AVVERTIMENTO - Questo accessorio a basso voltaggio non deve essere azionato da un oscuratore graduale che non sia specificamente tarato ed adatto per apparecchi a basson voltaggio.  
**LET OP - Deze laagvoltarmatuur niet dimmen, tenzij de dimmer geschikt is voor laagvolt systemen.**

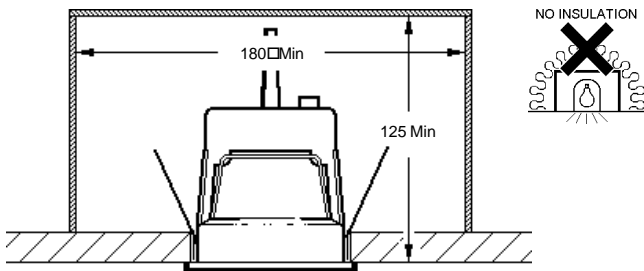
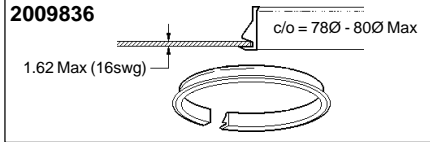

2642008 2642009 2642010 2642011

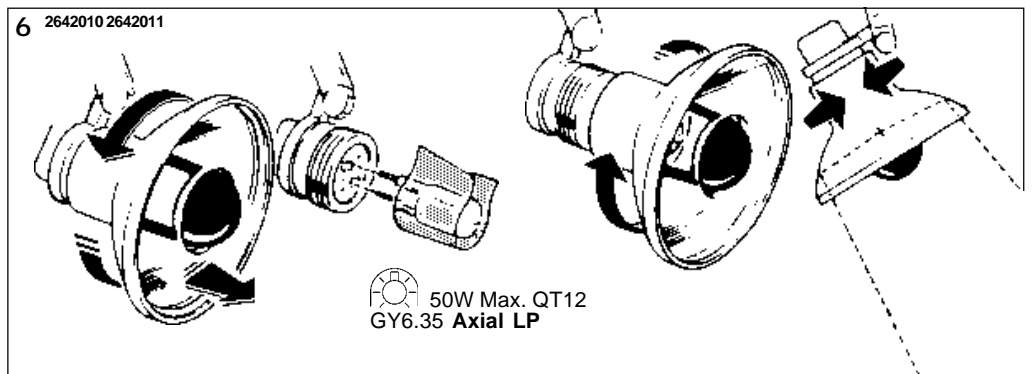
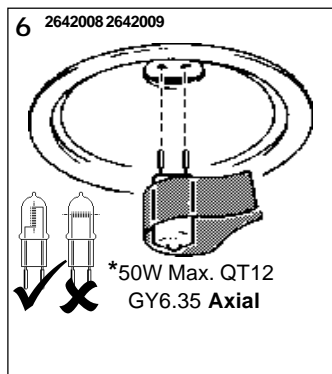
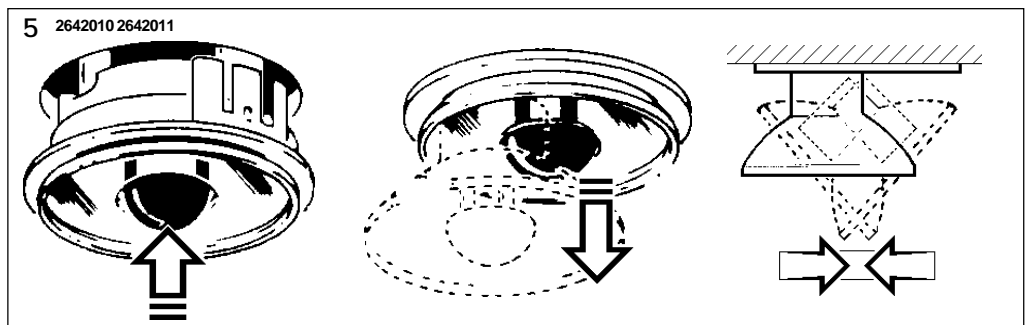
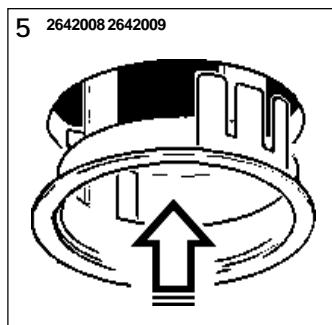
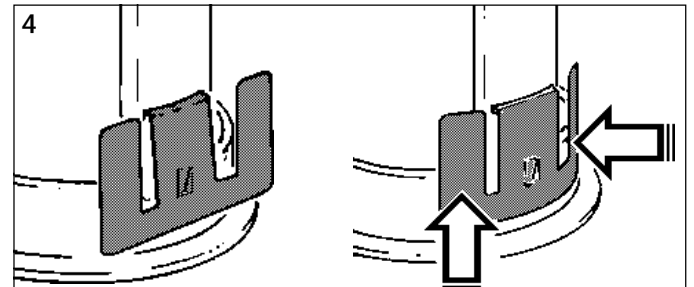
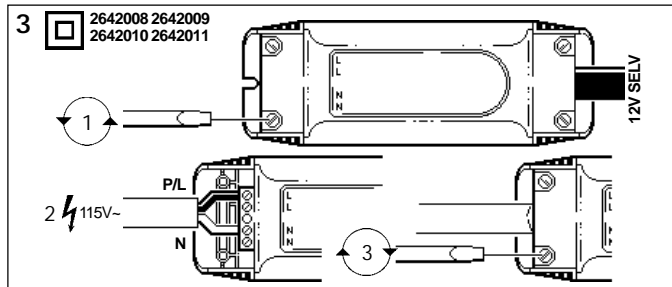
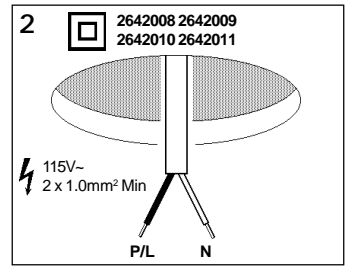
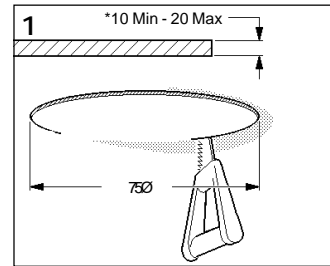

**Accessories**

**Spilling:**

2017392 2017393 2017394  
2017395 2017396

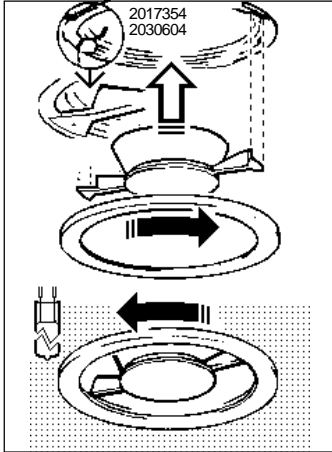

**Decorative Ring - IP44:**

2017356 2017357 2017358  
2017359 2017347 2017346

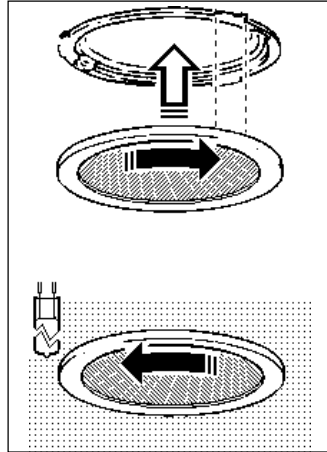

**Shallow Dish - IP44:**

2017373 2017374 2017375  
2017376

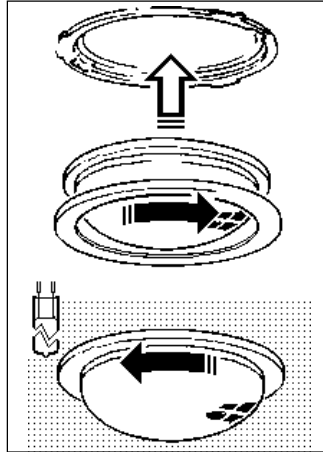

**Floating Glass:**

2017400 2017401 2017402

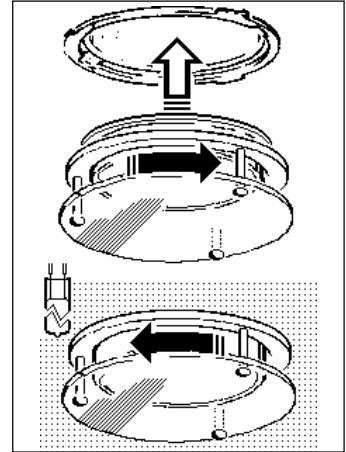

**Kick Reflector - IP44**

2017397 2017398 2017399

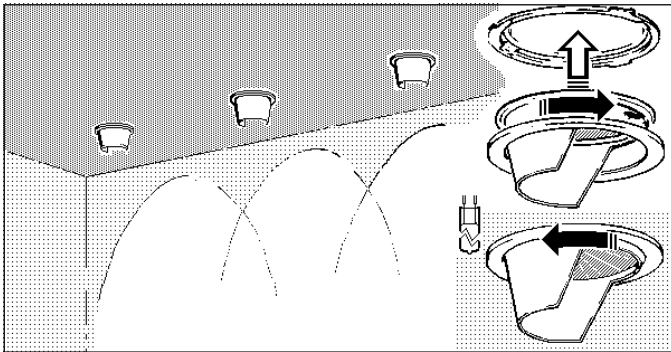

**Shallow Ring :**

2017360 2017361 2017362 2017363

**Glow Ring:**

2017380 2017382 2017384 2017381 2017383 2017385

**Deep Decorative Ring:**

2017364 2017365 2017367 2017369 2017371 2017366

2017368 2017370 2017372

Pinhole:  12V 50W Max QT12 GY6.35 Axial LP

2135030 2135040 2135090 2135130 2135140 2135190

2030621 2030622 2030623 2030624 2030625 2030626

**Metal Ring:**

2017377 2017378 2017379

\*  - Luminaires designed for use with self-shielded tungsten halogen lamps only.

Myriad is a registered trademark of Concord Lighting Limited. These products are protected by the following trademark registrations:  
U.K.-1307938, Benelux-433598, International-525070, Sweden-209849, Finland-105583, Norway-136800, Denmark-6177/1989, Japan-2509585.

**Suitable for use indoors**

Geeignet für Innenanwendung

Pour un usage interne

Adecuada para uso en interiores

Geschikt voor gebruik binnen

Lämplig för inomhusbruk



**Replace any cracked protective shield.**

Dieses symbol bedeutet, dass defekte Schutzgläser sofort ersetzt werden müssen.

**Ce symbol indique que vous devez remplacer tout verre de protection fêlé.**

Este simbolo indica que hay que reemplazar filtros en caso de rotura o desperfectos.

**Dette symbolet indikerer at alle ødelagte (sprukne) sikkerhetsglass må skiftes.**

Valaisinta el saa käyttää ilman suojalasia vioitunut suojalasi on vaihdettava uuteen ennen valaisimen käyttöön ottoa.



< Millimetres >



This Electrical Product  
MUST be recycled.



04.08

**Concord**

Avis Way Newhaven East Sussex BN9 0ED  
T 0870 606 2030 F 01273 512 688 email: information@concordmarlin.com

