

Decade Recessed Flush Plaster Gimbal

Installation Instructions
 IS500



This Product
MUST be EARTHED

IS1254B

2041859 - 7.90Kgs
 2041860 - 7.90Kgs
 2041861 - 7.90Kgs
 2041862 - 7.90Kgs

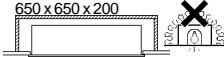

Disconnect from mains supply before replacing the fuse or the lamp.
 Vor dem Einsetzen der Sicherung oder der Lampe Spannungsfreiheit herstellen.
Débrancher le secteur avant de remplacer le fusible ou l'ampoule.
 Desconectar del suministro de la red, antes de realizar la sustitución del fusible o de la lámpara.
Voor het vervangen van lamp of zekering, eerst netspanning uitschakelen.
 Koppla bort spänningen före byte av en säkring eller en lampa.

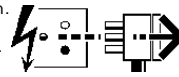

Switch Off
 Abschalten
Débrancher
 Desconectar
Uitschakelen
 Stäng av

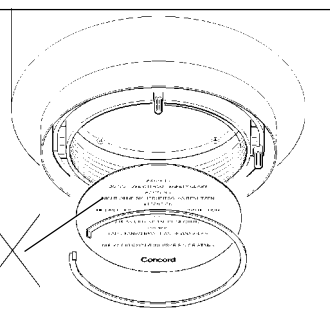
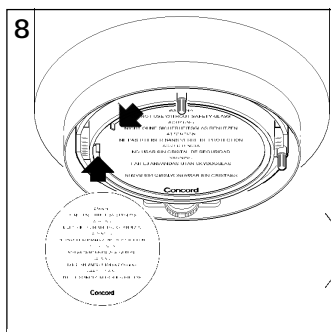
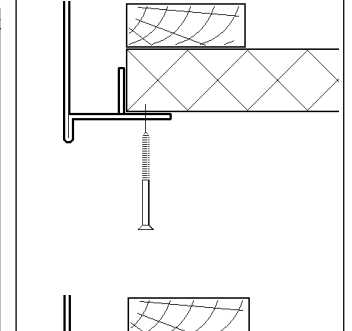
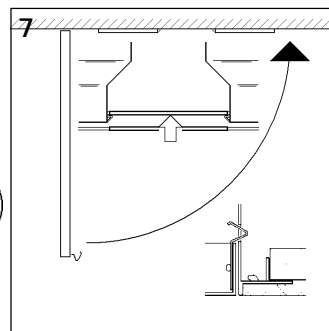
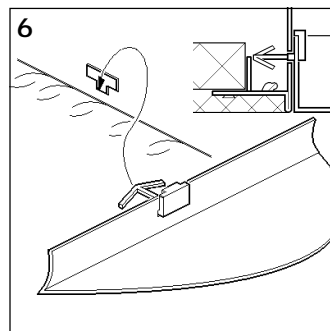
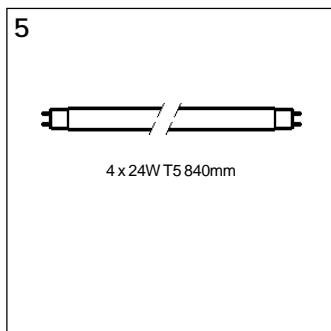
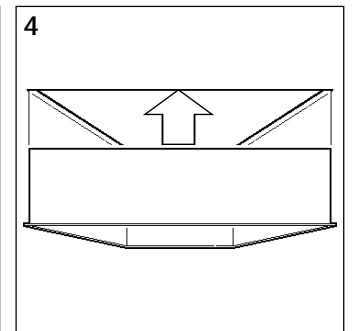
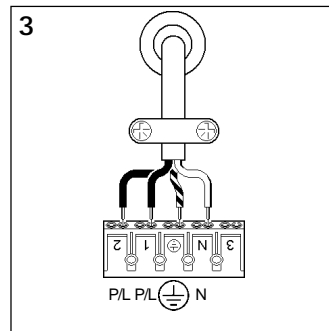
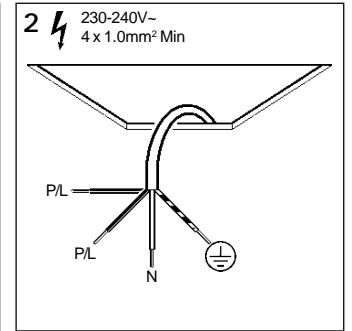
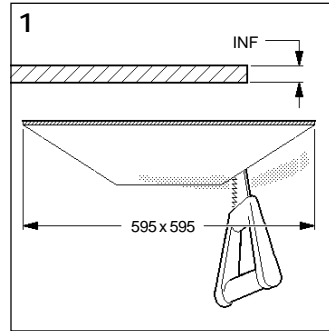
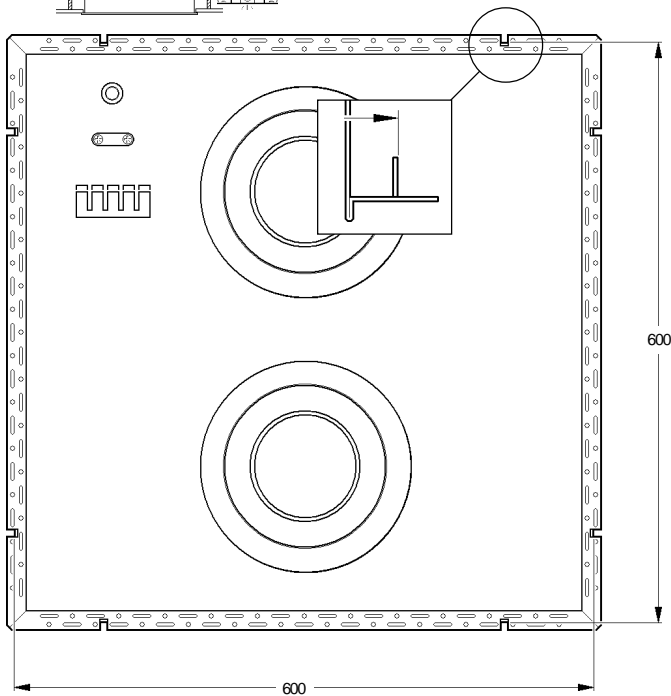

WARNING
 DO NOT USE WITHOUT SAFETY GLASS
ACHTUNG
 NICHT OHNE SICHERHEITSGLAS BENUTZEN
ATTENTION
 NE PAS UTILISER SANS VERRRE DE PROTECTION
ADVERTENCIA
 NO USAR SIN CRISTAL DE SEGURIDAD
VARNING
 FÄR EJ ANVÄNDAS UTAN SKYDDSGLAS
WAARSCHUWING
 NIET GEBRUIKEN ZONDER VEILIGHEIDGLAS

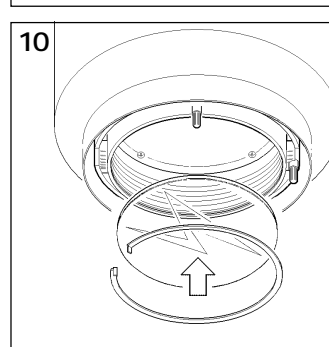
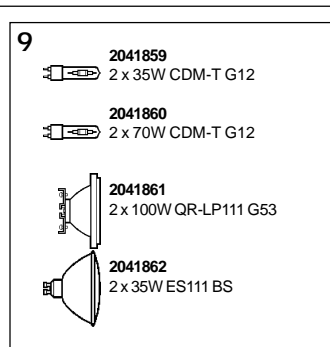

SAFETY GLASS

- 11° - Spot - 2027238
- 29° - Flood - 2027234
- 5:1 - Elongation - 2027239
- Honeycomb - 2027240

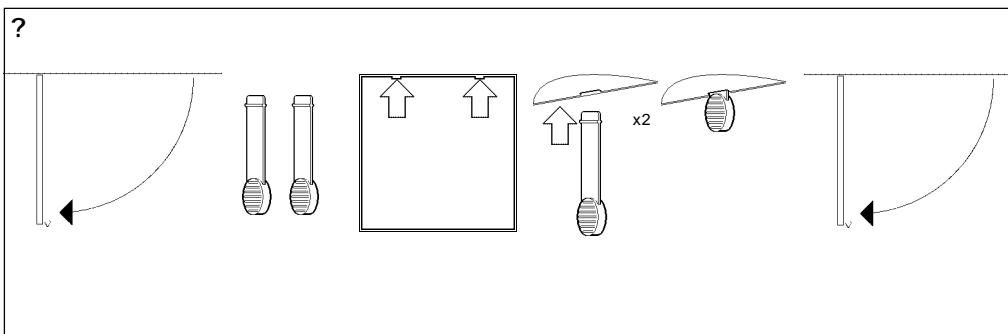
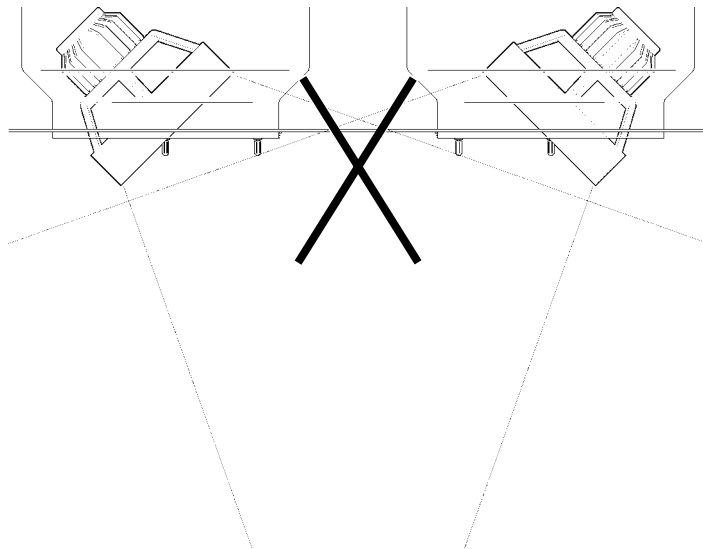
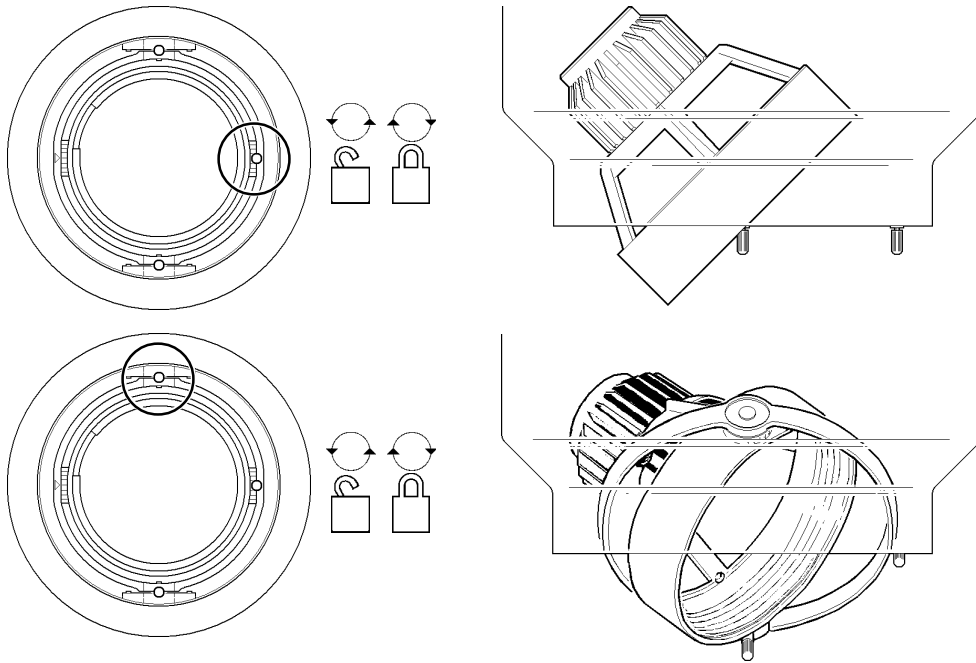

Suitable for use indoors
 Geeignet für Innenanwendung
Pour un usage interne
 Adecuada para uso en interiores
Geschikt voor gebruik binnen
 Lämplig för inomhusbruk



Replace any cracked protective shield.
 Dieses Symbol bedeutet, dass defekte Schutzgläser sofort ersetzt werden müssen.
Ce symbol indique que vous devez remplacer tout verre de protection fêlé.
 Este símbolo indica que hay que 'reemplazar filtros en caso de rotura o desperfectos'.
Dette symbolet indikerer at alle ødelagte (sprukne) sikkerhetsglass må skiftes.
 Valaisinta el saa käyttää ilman suojalasia vioitunut suojalasi on vaihdettava uuteen ennen valaisimen käyttöön ottoa.

< Millimetres >



This Electrical Product
MUST be recycled.



10.08

Concord

Avis Way Newhaven East Sussex BN9 0ED
 T 0870 606 2030 F 01273 512 688 email: information@concordmarlin.com



© Concord Lighting Ltd.