

Disconnect from mains supply before replacing the fuse or the lamp.
 Vor dem Einsetzen der Sicherung oder der Lampe Spannungsfreiheit herstellen.
Débrancher le secteur avant de remplacer le fusible ou l'ampoule.
 Desconectar del suministro de la red, antes de realizar la sustitución del fusible o de la lámpara.
Voor het vervangen van lamp of zekering, eerst netspanning uitschakelen.
 Koppla bort spänningen före byte av en säkring eller en lampa.

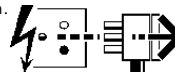

Switch Off
 Abschalten
Débrancher
 Desconectar
Uitschakelen
 Stäng av

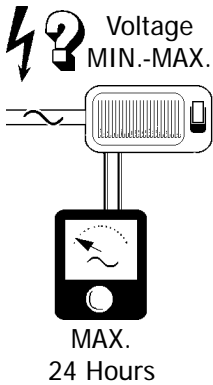

HIT(CDM-T)

35W
 2020400
 2020401
 2020402
 2020403
 2020404
 2020405

HQI

70W **150W**
 2010809 2010823
 2010816 2010829
 2010812 2010826
 2010819 2010832
 2010847 2010851
 2010849 2010853
 2010810 2010824
 2010817 2010830

WS

100W
 2010835
 2010841
 2010838
 2010844
 2010856
 2010858
 2010836
 2010842

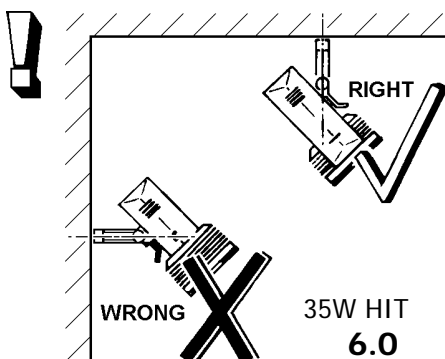
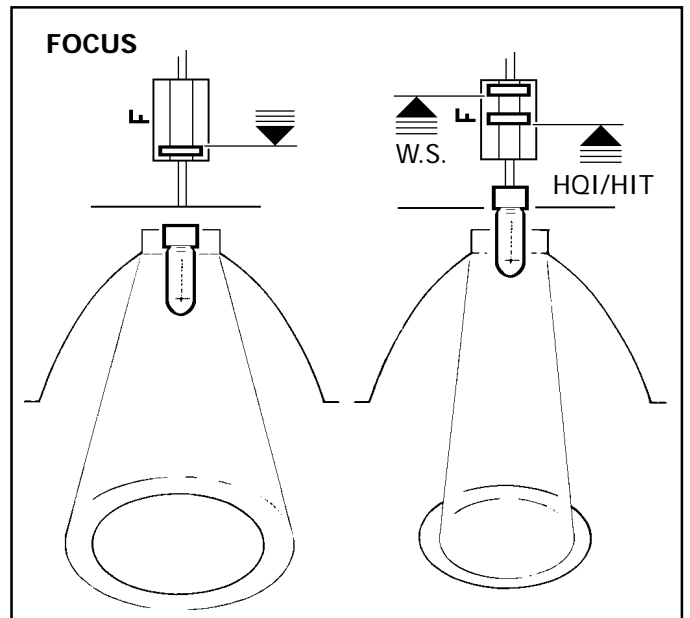
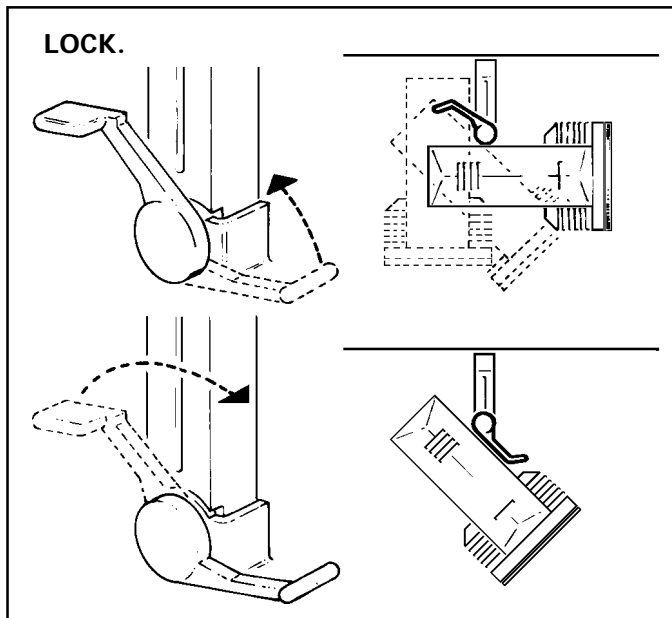
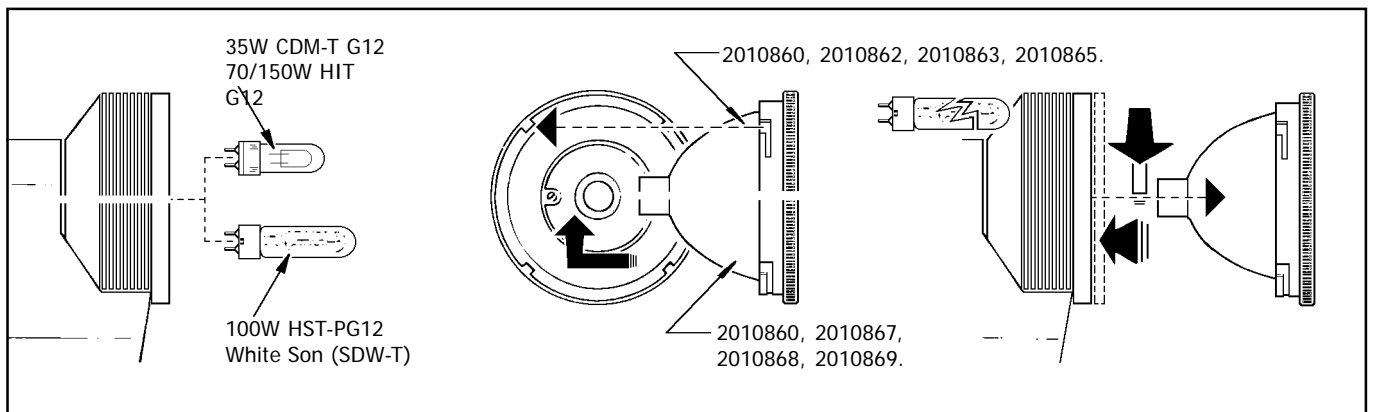
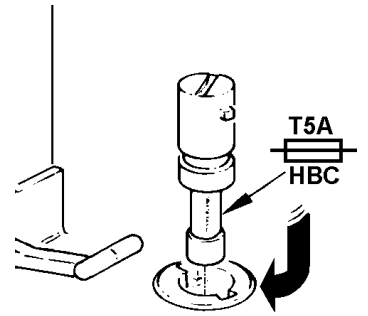
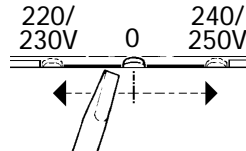
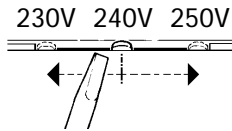

	Kg			
35W HIT	6.0	70W HQI	150WHQI	100W WS
		6.25	7.10	4.75

Accessories.....

2010940, 2010942.

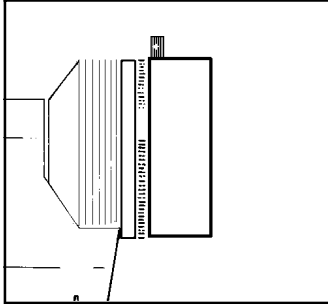

2010934, 2010935.

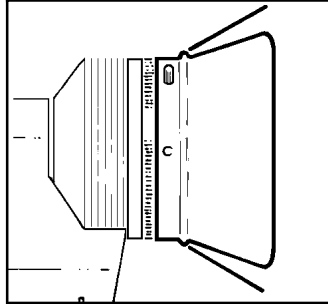

2010938, 2010939

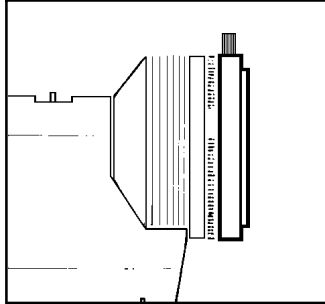

2010936, 2010937.

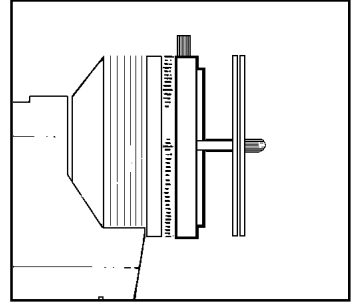

2010940, 2010942 +
2010938, 2010939.

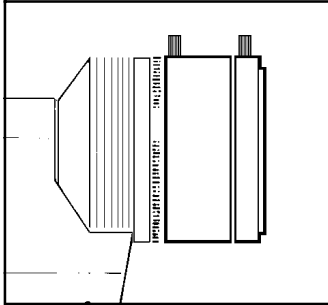

2010940, 2010942 +
2010936, 2010937.

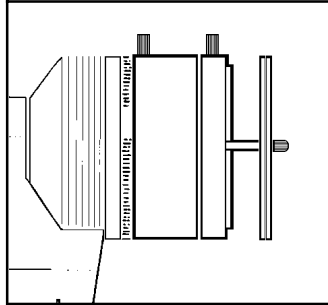

2010934, 2010935 +
2010938, 2010939.

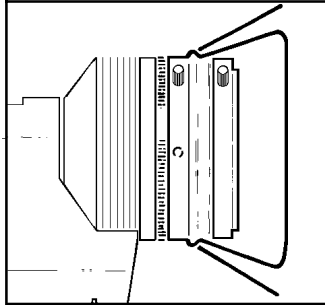

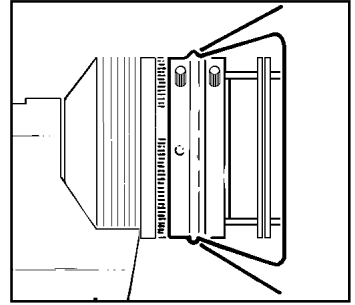

2010934, 2010935 +
2010936, 2010937.

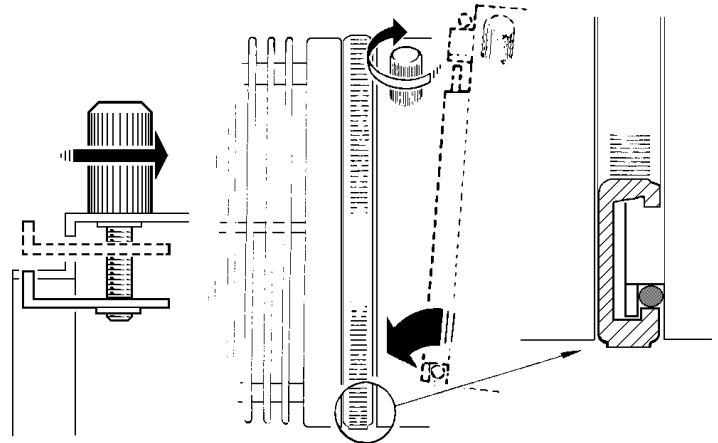
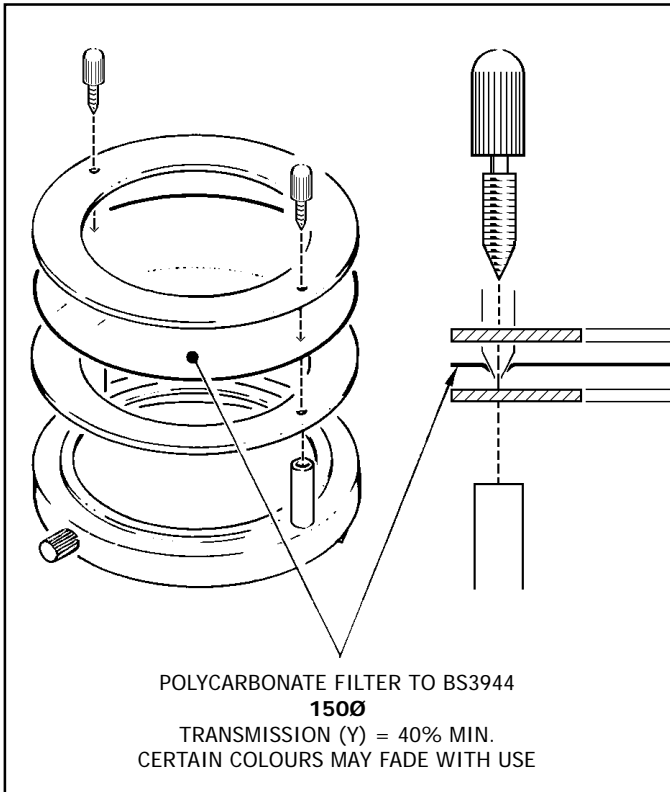

2010936, 2010937.



-  **Replace any cracked protective shield.**
Dieses symbol bedeutet, dass defekte schutzgläser sofort ersetzt werden müssen.
- Ce symbole indique que vous devez remplacer tout verre de protection fêlé.**
Este simbolo indica que hay que reemplazar filtros en caso de rotura o desperfectos.
-  **Dette symbolet indikerer at alle ødelagte (sprukne) sikkerhetglass må skiftes.**
Valaisinta el saa käyttää ilman suojalasia vioitunut suojalasi on vaihdettava uuteen ennen valaisimen käyttöön ottoa.

Suitable for use indoors
Geeignet für Innenanwendung
Pour un usage interne
Adecuada para uso en interiores
Geschikt voor gebruik binnen
Lämplig för inomhusbruk

< Millimetres >



Concord:marlin

Avis Way Newhaven East Sussex BN9 0ED
T 0870 606 2030 F 01273 512 688 email: information@concordmarlin.com

