

Luminaire Only

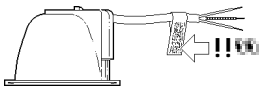

IP44
2033457 2033458
IP23
2033475 2033476

Disconnect from mains supply before replacing the fuse or the lamp.
Vor dem Einsetzen der Sicherung oder der Lampe Spannungsfreiheit herstellen.
Débrancher le secteur avant de remplacer le fusible ou l'ampoule.
Desconectar del suministro de la red, antes de realizar la sustitución del fusible o de la lámpara.
Voor het vervangen van lamp of zekering, eerst netspanning uitschakelen.
Koppla bort spänningen före byte av en säkring eller en lampa.

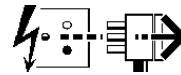

Switch Off
Abschalten
Couper le connectar
Desconectar
Uitschakelen
Stäng av

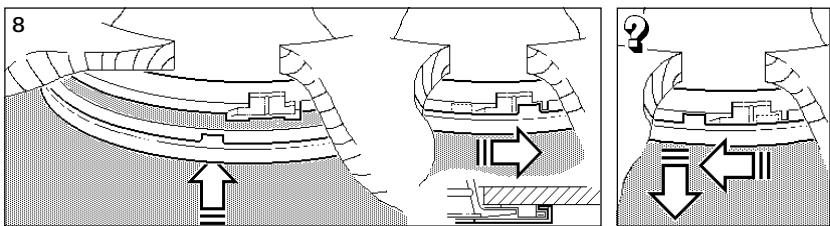
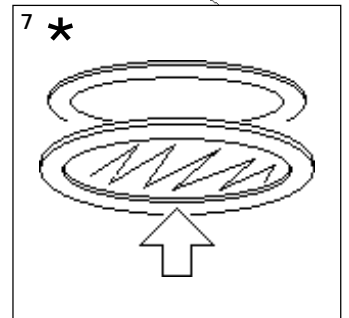
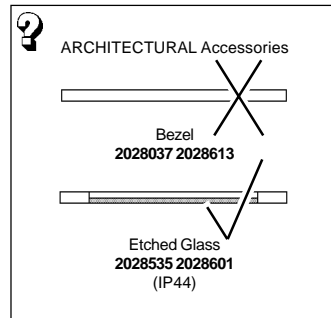
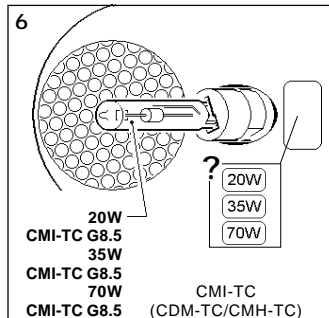
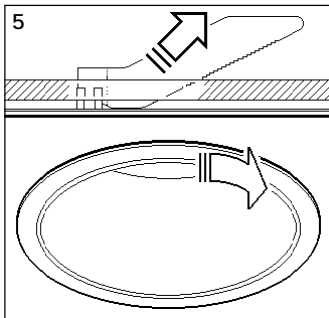
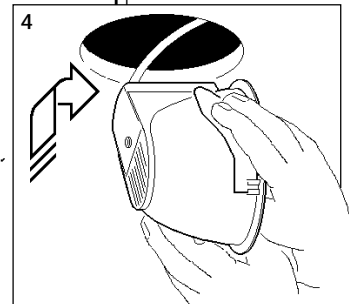
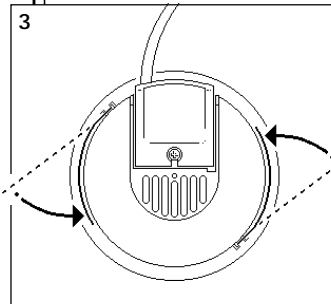
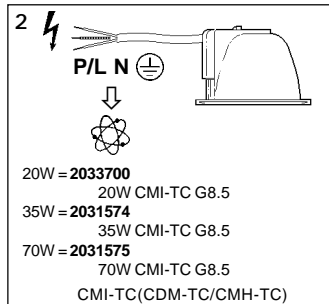
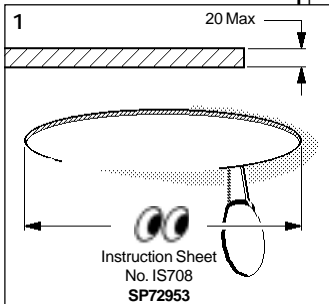
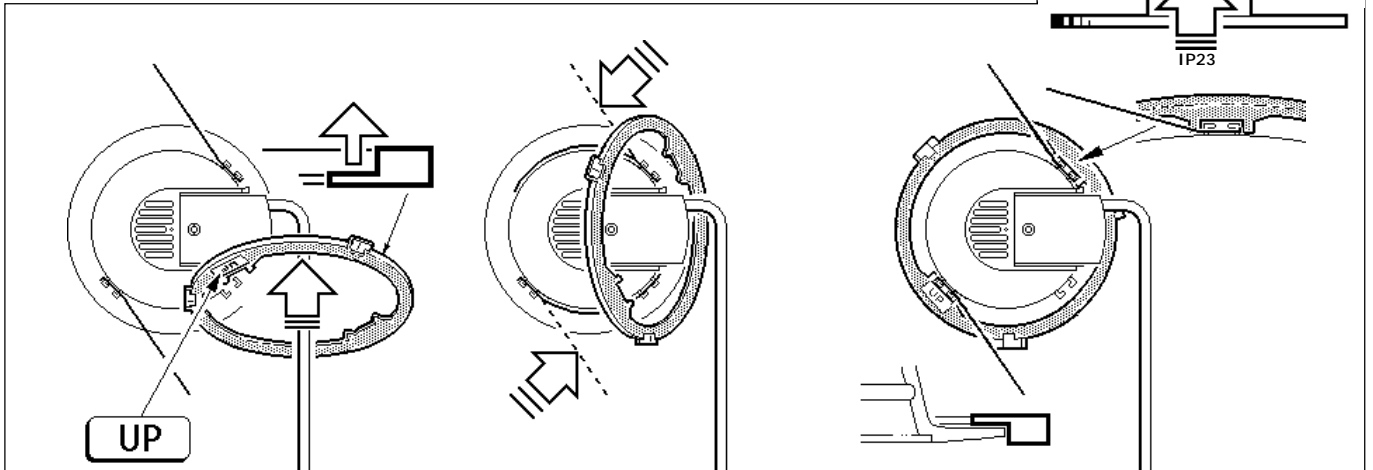
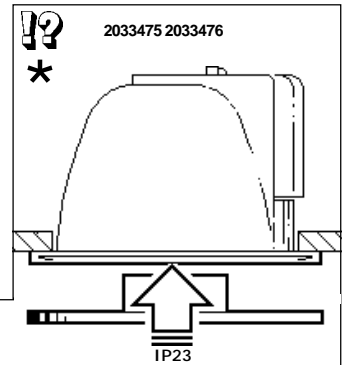
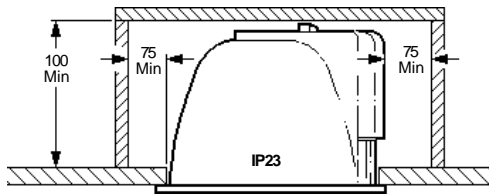
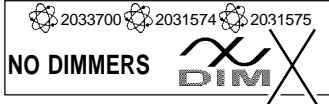

LED is a registered trade mark: UK2009652 A&B, International 659097 and is protected by the following Design Registration: Taiwan 85302887

Suitable for use indoors
Geeignet für Innenanwendung
Pour un usage interne
Adecuada para uso en interiores
Geschikt voor gebruik binnen
Lämpig för inomhusbruk

Replace any cracked protective shield.
Dieses symbol bedeutet, dass defekte Schutzgläser sofort ersetzt werden müssen.
Ce symbole indique que vous devez remplacer tout verre de protection fêlé.
Este simbolo indica que hay que reemplazar filtros en caso de rotura o desperfectos.
 Detta symbolet indikerer at alle ødelagte (sprukne) sikkerhetglass må skiftes.
Valaisinta ei saa käyttää ilman suojalasia vioitunut suojalasi on vaihdettava uuteen ennen valaisimen käyttöön ottoa.

< Millimetres >

This Electrical Product MUST be recycled.

