

Disconnect from mains supply before replacing the fuse or the lamp.
 Vor dem Einsetzen der Sicherung oder der Lampe Spannungsfreiheit herstellen.
Débrancher le secteur avant de remplacer le fusible ou l'ampoule.
 Desconectar del suministro de la red, antes de realizar la sustitución del fusible o de la lámpara.
Voor het vervangen van lamp of zekering, eerst netspanning uitschakelen.
 Koppla bort spänningen före byte av en säkring eller en lampa.

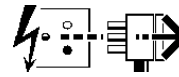

Switch Off
 Abschalten
Débrancher
 Desconectar
Uitschakelen
 Stäng av

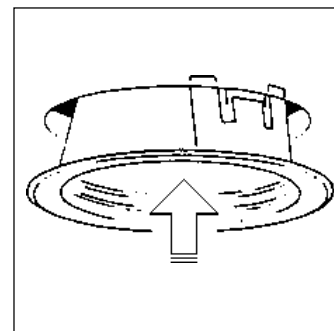
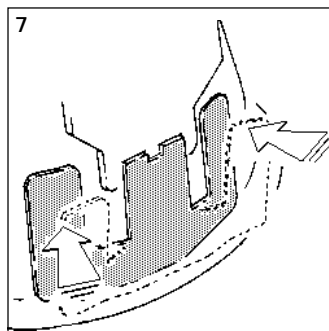
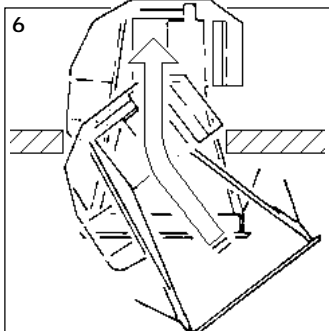
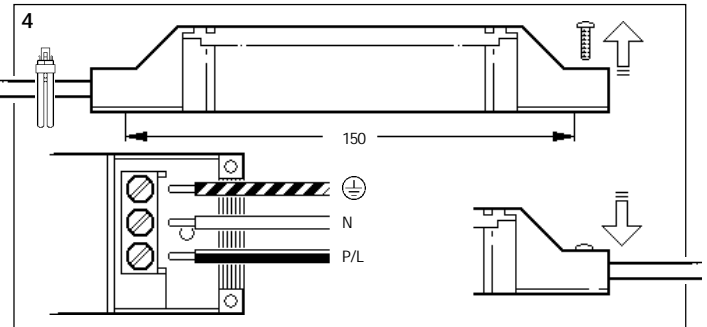
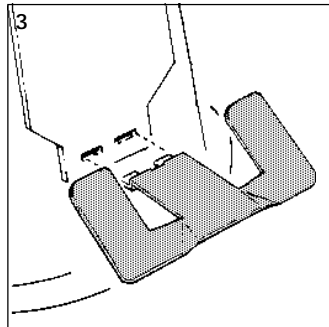
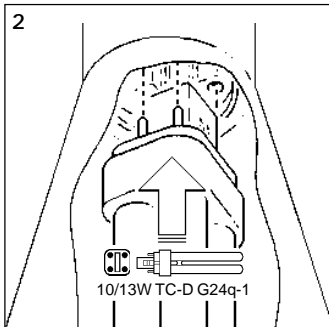
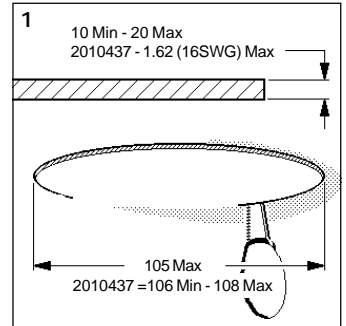
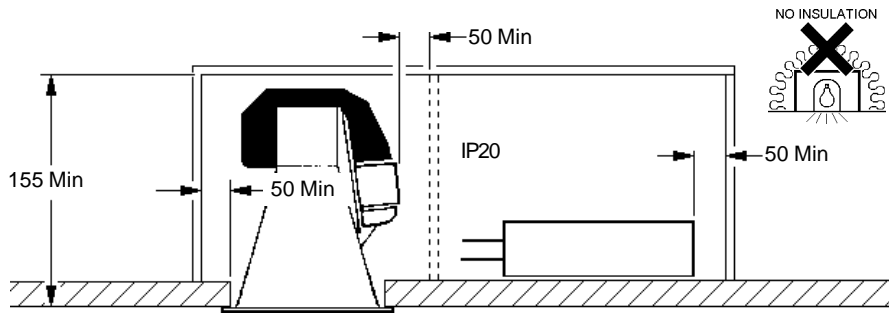

Suitable for use indoors
 Geeignet für Innenanwendung
Pour un usage interne
 Adecuada para uso en interiores
Geschikt voor gebruik binnen
 Lämplig för inomhusbruk



Replace any cracked protective shield.

Dieses symbol bedeutet, dass defekte Schutzgläser sofort ersetzt werden müssen.

Ce symbole indique que vous devez remplacer tout verre de protection fêlé.

Este símbolo indica que hay que reemplazar filtros en caso de rotura o desperfectos.



Dette symbolet indikerer at alle ødelagte (sprukne) sikkerhetglass må skiftes.

Valaisinta ei saa käyttää ilman suojalasiasa vioitunut suojalasi on vaihdettava uuteen ennen valaisimen käyttöön ottoa.

< Millimetres >



This Electrical Product MUST be recycled.



07.08